

УДК 616

HIERARCHICAL DATA PROCESSING MODELS AND EXPERT SYSTEMS FOR DECISION-MAKING IN TECHNICAL SYSTEMS

L. S. Sikora¹, O. Yu. Fedevych², B. I. Fedyna³, R. D. Karpyn⁴, Yu. M. Lysyi⁵

¹Lviv Polytechnic National University, 12, Stepana Bandery, St., Lviv, 79013, Ukraine
e-mail: liubomyr.s.sikora@lpnu.ua

²Lviv Polytechnic National University, 12, Stepana Bandery, St., Lviv, 79013, Ukraine
e-mail: olha.y.fedevych@lpnu.ua

³Lviv Polytechnic National University, 12, Stepana Bandery, St., Lviv, 79013, Ukraine
e-mail: bohdana.i.fedyna@lpnu.ua

⁴Lviv Polytechnic National University, 12, Stepana Bandery, St., Lviv, 79013, Ukraine
e-mail: roman.d.karpyn@lpnu.ua

⁵Lviv Polytechnic National University, 12, Stepana Bandery, St., Lviv, 79013, Ukraine
e-mail: yurii.m.lysyi@lpnu.ua

The paper addresses the problems of controlling complex technical and organizational–technical systems operating under boundary conditions, where uncertainty, failure risks, and the influence of external disturbances increase significantly. Particular attention is paid to models for processing and analyzing data on the current state of potentially hazardous objects (PHOs), with a focus on printing enterprises characterized by complex production processes, the use of chemical substances, energy-intensive equipment, and increased requirements for safety and product quality. Approaches to the formalization of states of printing production systems and the identification of critical parameters determining transitions to boundary operating modes of printing equipment, ventilation systems, and auxiliary infrastructure are proposed. Models for processing heterogeneous, incomplete, and noisy data obtained from technological, environmental, and production subsystems of the enterprise are considered. Methods for synthesizing control strategies that take into account multicriteria decision-making, time constraints, and the hierarchical structure of decision processes at printing enterprises are investigated. Data processing approaches at different levels of the management hierarchy are described, enabling the coordination of local technological decisions with global objectives of safety, economic efficiency, and environmental sustainability. To enhance the validity of managerial decisions, the use of expert systems combining formalized mathematical models with practical knowledge of specialists in the printing industry is proposed. It is shown that the integration of intelligent data analysis methods, expert assessments, and hierarchical control models improves the responsiveness, reliability, and adaptability of decision support systems under boundary operating conditions of printing enterprises.

Keywords: control, system, operating modes, functioning, methods, intelligent analysis.

Problem setting. The current state of development of production systems in the printing industry, energy sector, and other industrial domains is characterized by the intensification of technological operating modes, increasing complexity of control systems based on computerized industrial automation systems (SCADA / APCS), and the aging of production units, aggregates, and structural components, which collectively increases the risk of abnormal operating conditions. An additional risk factor is the insufficient professional level of operational personnel due to the obsolescence of their professionally oriented knowledge. Another significant risk factor is the inadequate cognitive capacity of operators during decision-making processes, as well as psychological instability under emergency or boundary operating conditions at potentially hazardous facilities.

The implementation of computerized control systems alone does not fully solve the problem of control in crisis situations, since conventional control strategies are primarily designed to ensure normal operating modes. When process parameters exceed predefined control limits, automated process control systems typically shut down the technological process. Moreover, certain technological parameters cannot be continuously monitored in real time.

The use of expert systems (ES) is based on the correct and constructive development of a knowledge base comprising fundamental knowledge, domain-specific expertise, logical and intelligent situation interpreters, and a decision support subsystem. The cognitive component of expert systems involves a domain expert, a knowledge engineer, and an intelligent agent (operator), who themselves may introduce additional risk factors due to incorrect or delayed decisions.

Accordingly, a relevant problem can be formulated concerning the synthesis of hierarchical automated process control systems integrating expert knowledge in order to improve the quality of control of potentially hazardous objects under boundary operating conditions, through the application of advanced information and laser-based technologies.

Analysis of Recent Research and Publications. The modern development of intelligent systems is based on the integration of classical artificial intelligence approaches with modeling methods and decision support in complex systems. The fundamental principles of this field are presented in the work by S. Russell and P. Norvig [1], which is one of the most comprehensive and systematized sources on the theory and practice of artificial intelligence. The authors consider the main AI paradigms, including search, logical inference, machine learning, reasoning under uncertainty, and intelligent agent systems, which forms a theoretical basis for further research.

A classical approach to artificial intelligence is presented in the work by N. Nilsson [2], where symbolic methods, heuristic search, and logical models of reasoning are analyzed in detail. Despite the year of its first publication, the reprint of this work confirms its relevance as a fundamental source for understanding the evolution of intelligent systems and the limitations of traditional methods.

In [3], the interrelationship between fuzzy sets, neural networks, and evolutionary algorithms is revealed, which made it possible to develop hybrid models for solving complex applied problems in poorly structured environments.

The authors of [4] propose a concept of knowledge representation in the form of information granules, which increases model interpretability and the efficiency of decision-making under conditions of limited or vague information.

In [5], it is shown that the integration of neural networks, fuzzy logic, evolutionary methods, and expert systems makes it possible to achieve higher accuracy and adaptability compared to the use of individual methods.

The authors of [6] emphasize intelligent decision support systems that employ multicriteria methods, fuzzy models, and expert knowledge to improve the soundness of managerial decision-making.

Book [7] presents practical aspects of the construction and application of Bayesian networks for risk analysis, forecasting, and decision support, which makes them an effective tool in modern intelligent systems.

The analysis of the cited sources indicates a clear trend toward the integration of various artificial intelligence methods aimed at creating adaptive, interpretable, and reliable decision support systems. The obtained scientific results form a theoretical and methodological basis for further research in the field of intelligent and hybrid systems.

Analysis of the cognitive component of expert systems. Several aspects of knowledge formation as the cognitive component of an expert system are considered.

Within the structure of an expert system (ES), the following components of intellectual activity can be distinguished [1–4]:

- dialogue component;
- explanation component;
- knowledge acquisition component.

In addition, the following information and processing structures are identified:

- knowledge base;
- knowledge and rule base;
- situation assessment processor (interpreter);
- task dispatcher;
- processor for the formation and selection of decisions based on a set of admissible strategies;
- an interpreter that determines how inference rules are applied to derive new knowledge based on operational information and fundamental theories.

Accordingly, the decision search mode under risk conditions is based on a dialogue between the intelligent agent, the expert system, and the automated process control system (IA–ES–APCS), in accordance with the scheme shown in Fig. 1.

The formation of control decisions for potentially hazardous objects (PHOs) is based, in real time, on the following components:

- control algorithms embedded in automated process control systems (APCS), implemented in real time in accordance with target strategies;
- the knowledge of intelligent agents (IA), i.e., control operators, acting according to operational plans and production tasks in compliance with the current operating mode of the PHO;

formation of situation images in the state space and target space; evaluation of metrics (distance to boundary operating modes and to the target region), assessment of proximity to the risk zone; and transmission of processed information to the decision formation block.

- Control stage – expert assessment of the risk level; evaluation of the dynamic situation with respect to the target region based on the selection of alternatives according to the partitioning of the target space; selection of the trajectory of state evolution of the potentially hazardous object (PHO) in accordance with control strategies, which is based on a hypothesis-testing procedure

$$\exists \text{Strat}(U / V(C_i)) \left\{ H_j : \hat{\Theta}_{t_k} \in V_x(L_R) \Rightarrow \text{Sit}_{j_k} \left(t_k / \hat{\Theta} \right) \right\} \\ \Rightarrow \left\{ H_i : \text{Sit}_{j_k} \left(t_k / \hat{\Theta} \right) \rightarrow K_u(PL_d) \right\},$$

where U denotes the control action, $V(C_i)$ is the target region (or target functional), H_j , H_i are hypotheses, $\hat{\Theta}_{t_k}$ is the estimated state at time t_k , $V_x(L_k)$ is the boundary operating region, and $K_u(PL_d)$ is the control command generated in accordance with the action plan [5].

- Execution stage – in accordance with the dynamics of target-oriented behavior implemented through the selected strategies, control commands are executed by actuating mechanisms that regulate resource flows. The control scheme of the potentially hazardous object (PHO) is shown in Fig. 2.

Accordingly, the following notations are used in the scheme (Fig. 2):

- DR_{ie} – source of energy resources;
- (R_{ij}, R_{2j}, R_m) – resource flow regulation system;
- (BM_E, BM_T, BM_F) – actuating mechanisms driving the regulators;
- ER – energy reactor;
- TR – technological reactor;
- V_i – resource flows, $V_i = V_i(t, \xi_i)$ under disturbances ξ_i ;
- FM – product forming mechanisms;
- $\{\theta_R, \theta_i, \theta_r, \theta_f, \theta_p, \theta_k\}$ – state parameters of technological operating modes of PHO aggregates;
- APCS–ER – automated process control system for energy resource management of the reactor;
- APCS–TR – automated process control system for technological reactor operating modes;
- APCS–FF – automated process control system for forming mechanisms;
- $\text{Strat}U_i$ – strategies for generating control decisions under target-oriented operation;
- APCS–C – automated coordination control system based on selected upper-level hierarchical strategies;
- IA–T – intelligent operator at the technological level controlling PHO aggregates;
- IA–R – intelligent operator coordinating APCS operating modes;
- IA–E – intelligent agent–expert responsible for coordination control;
- ESDSS_C – expert system for coordinated decision support.

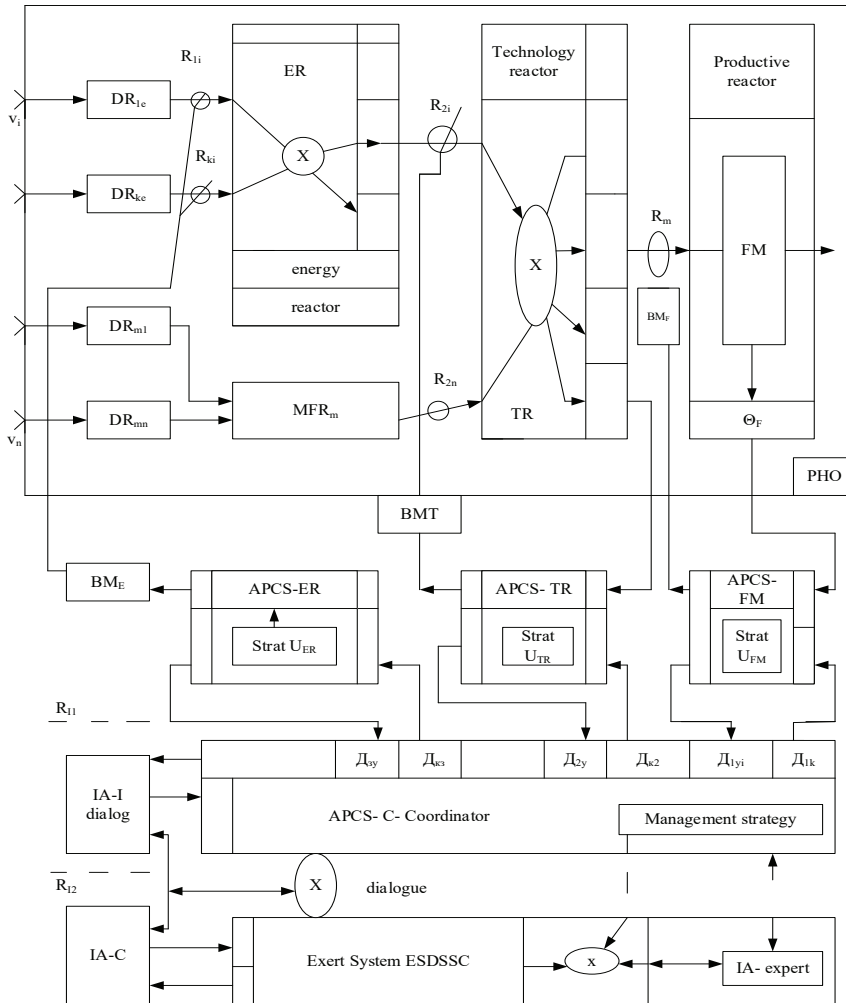

Fig. 2. Structural control scheme of aggregates of a potentially hazardous object with an ordered hierarchy

At the aggregate level, state parameters are defined for each block of the PHO structure. The admissible ranges of operating parameters must be consistent with the measurement scales of sensing and measurement transducers in terms of their dynamic and interval characteristics.

In the formation of local and strategic decisions, data streams and the results of their processing and analysis are used in accordance with the level of hierarchy and the system's decision-making authority.

Accordingly, an information and measurement system with a hierarchical intelligent structure is constructed. Within this framework, the following levels of data acquisition and processing of the technological process state of a potentially hazardous object (PHO) can be distinguished.

– Data acquisition level from PHO aggregates:

$$\langle A_{gR}^i | i = n \rangle_{T_m} \rightarrow \langle \theta_i(t), \theta_n(t), \forall t \in T_m \rangle$$

where the physical state parameter $\left\{ \begin{matrix} X_i(t), \forall t \in T_m \\ X_i \in I_x \end{matrix} \right\} \xrightarrow{K_{VP}} \left\{ \begin{matrix} \theta_i(t) = X_i K_{np} \\ \theta_i \in I_\theta \end{matrix} \right\}_{T_m, x_i = x(t)}$

corresponds to a normalized signal value θ_i at the output of the measurement transducer, provided that the measurement scales are properly matched:

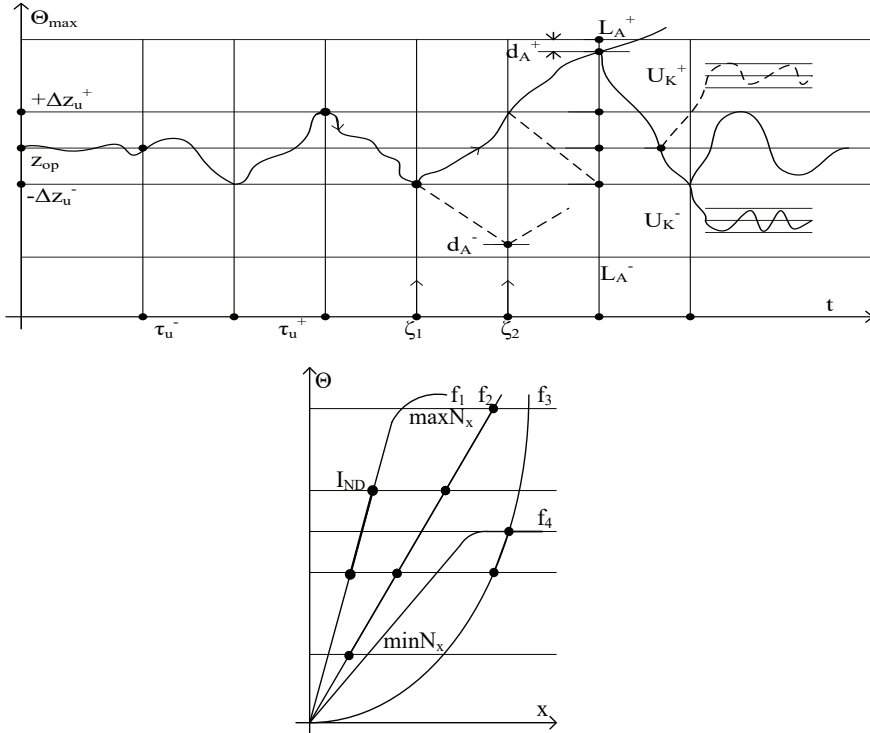

Fig. 3. Alignment of the measurement transducer range with the dynamics of the technological process in the state space

$$\begin{aligned} \forall (x, t), x \in I_x &\rightarrow K_{VP} \rightarrow I_\theta; I_{XR}^T \subset I_{\theta R}^T; \\ \min X &\rightarrow K_{VP} \rightarrow \min I_\theta; \\ \max X &\rightarrow K_{VP} \rightarrow \max I_\theta, \end{aligned}$$

where $[X_{max}, X_{min}] = I_{XR}^T$ is the technological process range.
 $[\theta_{max}, \theta_{min}] = I_{\theta R}^T$

Accordingly, the boundary and emergency values of the state parameter (expert assessments) must lie within the scale interval of the measurement transducers:

$L_A^+(\hat{\theta}_K) \leq \max I_\theta - \Delta_A, \max I_\theta, -$ scale maximum, $L_A^-(\theta_K) \geq \min I_\theta + \Delta_a$ where L_A^+, L_A^- represents the boundary operating region in the state space of the aggregate.

For normal technological operating modes defined by the production task, the parameter variation range must satisfy the following conditions:

- $[\hat{Z}_{op} + \Delta Z_u^+] \leq L_A^+(\hat{\theta}) - d_A^+, d_A^+$ – safety margin of the boundary distance to the emergency operating mode, within which the automated process control system (APCS) remains stable;
- $[\hat{Z}_{op} - \Delta Z_u^-] \geq L_A^-(\hat{\theta}_K) + d_a^+, d_A^+$ – safety margin of the boundary distance allowing potential recovery of the technological operating mode.

Control decisions at the APCS level are formed based on the current dynamic situation through the verification of the following conditions:

$$H_{1i} : (\hat{\theta}(t) \in [Z_{op} + \Delta Z_u^+, Z_{op} - \Delta Z_u^-]) \Rightarrow K_{op}^u(t, \tau_u);$$

$$H_{2i} : (\hat{\theta}(t) \notin [Z_{op} + \Delta Z_u^+, Z_{op} - \Delta Z_u^-]) \Rightarrow [StratU_K(C_i)],$$

where: $K_{op}^u(\)$ – control commands compensating deviations from the prescribed trajectory under condition H_{1i} :

$$K_{op}^u(t, \tau_u) : \begin{cases} H_{12i} \left\{ \theta(t) \geq \hat{Z}_{op} + \Delta Z_u^+ \right\} \Rightarrow K_1^u \\ H_{11i} \left\{ \theta(t) \leq \hat{Z}_{op} - \Delta Z_u^- \right\} \Rightarrow K_2^u \end{cases}$$

where K_1^u, K_2^u – control commands regulating resource flows in PHO aggregates.

In the case where condition H_{2i} is satisfied, control authority is transferred to a higher hierarchical level of APCS decision-making strategies, accompanied by an assessment of the PHO state in order to evaluate the availability of resources for strategic decision-making. The hierarchy levels of strategic decision-making for controlling a potentially hazardous aggregated object within a production structure represent the highest level in terms of management authority [6].

At the level of strategy correction of the automated process control system (APCS) based on situation assessment, the following procedures are applied:

$$H_{2i} : (\text{true Sit}) H_{2i}^+ : \hat{\theta}(t) \leq |L_A^+ - d_A^+| \Rightarrow K_1^+;$$

$$\exists Strat_1 U_k(C_i) H_{2i} : \hat{\theta}(t) \geq |L_A^- + d_A^-| \Rightarrow K_2^+.$$

If the stability margin condition is not satisfied, i.e., $H_{2j} : \hat{\theta}(t) > |L_A^+ - d_A^+|$, meaning that the system enters a pre-emergency operating mode, a corrective strategy must be applied to ensure exit from this state through the implementation of

$$ALARM : Strat(U_A^+ | \hat{\theta}(t) \rightarrow L_A^+) \Rightarrow \exists KL [K_A(U_i)]_{i=1}^m$$

$$\{K_A(U_1) \rightarrow K_A(U_2) \rightarrow \dots \rightarrow K_A(U_n): Z_A \rightarrow Z_n\}$$

where $\{K_A(U_i)|_{i=1,n}\} \subset KL[K_A(U_i)]_{i=1}^m$ denotes a sequence of commands from the class of coordinating anti-emergency control actions.

When the condition for the lower stability level is satisfied,

$$H_{2l}: \hat{\theta}(t) \leq |L_A^- + d_A^-| \Rightarrow [ALARM] \rightarrow \exists Strat \left(U_A^- / \theta(t) \rightarrow L_A^- \right) \Rightarrow$$

$$\exists KL[K_A stop]: \{K_A(ue): Z_A \rightarrow Z_o\}$$

emergency-safe shutdown commands are executed, which indicates a system malfunction or insufficient availability of resources.

From the above, the importance of information technologies for data processing and methods for strategy synthesis in the assessment of situations in potentially hazardous objects follows directly [7].

If for lower hierarchy levels, classical evaluation methods based on standard statistical measures are sufficient, such as

$$X_i \rightarrow Z_i, Z_i \rightarrow \theta_i, \hat{\theta}_{i+n} = \frac{1}{n} \sum_{i=1}^{i+n} \theta_i,$$

whereas for upper hierarchy levels it is necessary, based on the state space model and the target space model, to determine situational parameters and to evaluate boundary distances to emergency operating modes.

$$\mu^+(\hat{\theta}_i, L_A^+, d_A^+) = |L_A^+ - d_A^+| - \hat{\theta}_i;$$

$$\mu^-(\hat{\theta}_i, L_A^-, d_A^-) = |L_A^- + d_A^-| + \hat{\theta}_i;$$

trends $tend \hat{\theta}_i(\tau_i) = \hat{\theta}(t_{i+\tau}) - \hat{\theta}[t_i]$, on the basis of which an expert forecast of approaching the emergency zone is performed.

When the condition $H: (\mu^+(\hat{\theta}_i, L_A^+, d_A^+) \rightarrow 0) \Rightarrow Kom[Strat_A U_c]$ is satisfied, control is transferred at the strategic level to coordinating emergency response strategies.

Conclusions. The paper addresses the problem of control in hierarchical systems with potentially hazardous objects, particularly under boundary and emergency operating conditions. The selection of control strategies at different hierarchy levels is substantiated, taking into account the characteristics of information support, time constraints, and the multicriteria nature of decision-making. The feasibility of a differentiated approach to the formation of control actions is demonstrated, enabling the coordination of local and global system objectives.

For processing data on the current and emergency states of objects, appropriate algorithms for the analysis and integration of heterogeneous information are justified, ensuring increased reliability of state assessment and timely detection of critical situations. The proposed approaches form a basis for the development of decision support systems using expert systems, which enhances the responsiveness, reliability, and adaptability of control of potentially hazardous objects. The obtained results can be applied

in the design and modernization of automated control systems for industrial enterprises, particularly in the printing industry.

REFERENCES

1. Russell, S., & Norvig, P. (2021). *Artificial intelligence: A modern approach* (4th ed.).
2. Nilsson, N. J. (2018). *Principles of artificial intelligence* (Reprint ed.). Morgan Kaufmann.
3. Zadeh, L. A. (2019). *Fuzzy logic, neural networks, and soft computing*. World Scientific.
4. Pedrycz, W., & Chen, S.-M. (2015). *Granular computing and decision-making*. Springer.
5. Jain, L. C., & Shandilya, S. K. (2019). *Hybrid intelligent systems*. Springer.
6. Kahraman, C., & Yanik, S. (2021). *Intelligent decision support systems*. Springer.
7. Fenton, N., & Neil, M. (2019). *Risk assessment and decision analysis with bayesian networks* (2nd ed.). CRC Press.

СПИСОК ВИКОРИСТАНИХ ДЖЕРЕЛ

1. Russell S., Norvig P. *Artificial Intelligence: A Modern Approach*. 4th ed. Harlow: Pearson, 2021. 1136 p. http://lib.yzu.am/disciplines_bk/efdd4d1d4c2087fe1cbe03d9ced67f34.pdf.
2. Nilsson N. J. *Principles of Artificial Intelligence*. Reprint ed. Burlington: Morgan Kaufmann, 2018. 475 p.
3. Zadeh L. A. *Fuzzy Logic, Neural Networks, and Soft Computing*. Singapore: World Scientific, 2019. 1100 p.
4. Pedrycz W., Chen S.-M. *Granular Computing and Decision-Making*. Cham: Springer, 2015. 373 p.
5. Jain L. C., Shandilya S. K. *Hybrid Intelligent Systems*. Cham: Springer, 2019. 488 p.
6. Kahraman C., Yanik S. *Intelligent Decision Support Systems*. Cham: Springer, 2021. 531 p.
7. Fenton N., Neil M. *Risk Assessment and Decision Analysis with Bayesian Networks*. 2nd ed. Boca Raton : CRC Press, 2019. 544 p.

doi: 10.32403/1998-6912-2026-1-72-50-60

ІЄРАРХІЧНІ МОДЕЛІ ОБРОБКИ ДАНИХ ТА ЕКСПЕРТНІ СИСТЕМИ ДЛЯ ПРИЙНЯТТЯ РІШЕНЬ У ТЕХНІЧНИХ СИСТЕМАХ

Л. С. Сікора¹, О. Ю. Федевич², Б. І. Федина³, Р. Д. Карпин⁴, Ю. М. Лисий⁵

¹ Національний університет «Львівська політехніка»,
вул. Степана Бандери, 12, Львів, 79013, Україна
e-mail: liubotur.s.sikora@lpnu.ua

² Національний університет «Львівська політехніка»,
вул. Степана Бандери, 12, Львів, 79013, Україна
e-mail: olha.y.fedevych@lpnu.ua

³ Національний університет «Львівська політехніка»,
вул. Степана Бандери, 12, Львів, 79013, Україна
e-mail: bohdana.i.fedyna@lpnu.ua

⁴ Національний університет «Львівська політехніка»,
вул. Степана Бандери, 12, Львів, 79013, Україна
e-mail: roman.d.karpyun@lpnu.ua

⁵ Національний університет «Львівська політехніка»,
вул. Степана Бандери, 12, Львів, 79013, Україна
e-mail: yurii.m.lysyi@lpnu.ua

В роботі розглянуто проблеми управління складними технічними та організаційно-технічними системами в граничних режимах функціонування, коли зростає невизначеність, ризик відмов та вплив зовнішніх збурень. Особливу увагу приділено моделям обробки та аналізу даних про поточний стан потенційно небезпечних об'єктів (ПНО), зокрема поліграфічних підприємств, що характеризуються складними виробничими процесами, використанням хімічних речовин, енергоємного обладнання та підвищеними вимогами до безпеки й якості продукції. Запропоновано підходи до формалізації станів поліграфічних виробничих систем та ідентифікації критичних параметрів, які визначають перехід у граничні режими роботи друкарського обладнання, вентиляційних систем і допоміжної інфраструктури. Розглянуто моделі обробки різнорідних, неповних та зашумлених даних, що надходять від технологічних, екологічних і виробничих підсистем підприємства. Досліджено методи синтезу стратегій управління з урахуванням багатокритеріальності, часових обмежень та ієрархічної структури прийняття рішень на поліграфічних підприємствах. Описано способи опрацювання даних на різних рівнях ієрархії управління, що дозволяє узгоджувати локальні технологічні рішення з глобальними цілями безпеки, економічної ефективності та екологічної стійкості. Для підвищення обґрунтованості управлінських рішень запропоновано використання експертних систем, які поєднують формалізовані математичні моделі з практичними знаннями фахівців поліграфічної галузі. Показано, що інтеграція методів інтелектуального аналізу даних, експертних оцінок та ієрархічних моделей управління забезпечує підвищення оперативності, надійності та адаптивності систем підтримки прийняття рішень в умовах граничних режимів функціонування поліграфічних підприємств.

Ключові слова: управління, система, режими, функціонування, методи, інтелектуальний аналіз.

Стаття надійшла до редакції 02.03.2026.

Submitted: 02.03.2026.

Прийнято до друку: 25.03.2026.

Accepted: 25.03.2026.

Опубліковано: 30.05.2026.

Published: 30.05.2026.



This is an Open Access article distributed under the terms of the [Creative Commons CC-BY 4.0](https://creativecommons.org/licenses/by/4.0/)

© Л. С. Сікора, О. Ю. Федевич, Б. І. Федина, Р. Д. Карпин, Ю. М. Лисий